

No. 20-51016

**United States Court of Appeals
for the Fifth Circuit**

MICHAEL CARGILL,

Plaintiff-Appellant,

v.

MERRICK GARLAND, U.S. ATTORNEY GENERAL; UNITED STATES
DEPARTMENT OF JUSTICE; STEVEN DETTELBACH, IN HIS OFFICIAL CAPACITY
AS DIRECTOR OF THE BUREAU OF ALCOHOL, TOBACCO, FIREARMS AND
EXPLOSIVES; BUREAU OF ALCOHOL, TOBACCO, FIREARMS AND EXPLOSIVES,

Defendants-Appellees.

On Appeal from the United States District Court
for the Western District of Texas, Austin Division
No. 1:19-cv-349

**UNOPPOSED MOTION FOR LEAVE TO FILE BRIEF FOR
AMICI CURIAE FIREARMS POLICY COALITION AND FPC
ACTION FOUNDATION SUPPORTING APPELLANT AND
REVERSAL**

Cody J. Wisniewski
FIREARMS POLICY COALITION
5550 Painted Mirage Road, Suite 320
Las Vegas, NV 89149

Joseph G.S. Greenlee
FPC ACTION FOUNDATION
5550 Painted Mirage Road, Suite 320
Las Vegas, NV 89149

Erik S. Jaffe
Joshua J. Prince
Counsel of Record
SCHAERR | JAFFE LLP
1717 K Street NW, Suite 900
Washington, DC 20006
(202) 787-1060
jprince@schaerr-jaffe.com

Counsel for Amici Curiae

August 1, 2022

MOTION FOR LEAVE TO PARTICIPATE AS *AMICI*

Amici Firearms Policy Coalition and FPC Action Foundation move for leave to file a Brief supporting Appellant, Michael Cargill, to assist the Court's consideration of the claims at issue. All parties received notice of *Amici's* intent to file as required under Rule 29(2). No party opposed the filing of the Brief.

CORPORATE DISCLOSURE STATEMENT

Amici are both nonprofit organizations, no *Amicus* has a parent corporation, and no publicly held corporation owns 10% or more of either *Amicus*.

RULE 29(a)(4)(e) STATEMENT

No party's counsel authored this Motion or the accompanying Brief in whole or in part. Further, no party or party's counsel contributed money that was intended to fund their preparation or submission. Finally, no person, other than *Amici* or their counsel, contributed money that was intended to fund the preparation or submission of either this Motion or the proposed Brief.

IDENTITY AND INTEREST OF *AMICI CURIAE*

Firearms Policy Coalition (FPC) is a nonprofit organization devoted to advancing individual liberty and defending constitutional rights. FPC accomplishes its mission through legislative and grassroots advocacy, legal and historical research, litigation, education, and outreach programs. FPC's legislative and grassroots advocacy programs promote constitutionally based public policy. Its historical research aims to discover the Founders' intent and the Constitution's original meaning. And its legal research and advocacy aim to ensure that constitutional rights maintain their original scope.

FPC Action Foundation (FPCAF) is a nonprofit organization dedicated to preserving the rights and liberties protected by the Constitution. FPCAF focuses on research, education, and legal efforts to inform the public about the importance of constitutional rights—why they were enshrined in the Constitution and their continuing significance. FPCAF is determined to ensure that the freedoms guaranteed by the Constitution are secured for future generations. FPCAF is one of the Plaintiffs/Appellants in *Guedes v. ATF*, No. 21-05045

(D.C. Cir.), another case challenging ATF’s bump stock rule and currently awaiting decision by the D.C. Circuit.

ISSUES TO BE ADDRESSED BY *AMICI*

Amici address two points in their proposed Brief. First, they provide additional information about the process of bump firing to highlight the absurdity of the Final Rule’s definition of “machinegun.” As the Supplemental Brief explains, at 4, bump firing can be done without a bump stock. *Amici* expand upon how that is done and how any semiautomatic weapon can be bump fired by itself or with a multitude of commonly available materials that can make the process marginally easier. Given the intrinsic physics of such techniques, ATF’s definitions of “automatically” and of “single function of the trigger” would render *every* semiautomatic weapon a machinegun—an absurd result that cannot be squared with other statutory sections recognizing that semiautomatic weapons are a distinct and less-regulated category of weapons than machineguns.

Second, *Amici* address the district court’s Orwellian conclusion that the “trigger” of a bump-stock-equipped weapon is something other than the universally understood mechanism that typically interacts with the

human finger to release the hammer when depressed or “pulled” and then, on a semiautomatic weapon, resets the firing mechanism when released. Reclassifying the forebody of a weapon as the trigger because forward pressure on the forebody causes the actual trigger to interact with the trigger finger both defies any recognizable public meaning of the language of the statute and leads to absurd results.

CONCLUSION

Because the two points raised in *Amici*'s proposed Brief will assist this Court in deciding this case, *Amici* respectfully ask this Court to grant their Motion for leave to file their Brief.

Respectfully submitted,

/s/ Joshua J. Prince

Erik S. Jaffe

Joshua J. Prince

Counsel of Record

SCHAERR | JAFFE LLP

1717 K Street NW, Suite 900

Washington, DC 20006

(202) 787-1060

jprince@schaerr-jaffe.com

Cody J. Wisniewski

FIREARMS POLICY COALITION

5550 Painted Mirage Road,

Suite 320

Las Vegas, NV 89149

Joseph G.S. Greenlee

FPC ACTION FOUNDATION

5550 Painted Mirage Road,

Suite 320

Las Vegas, NV 89149

Counsel for Amici Curiae

Dated: August 1, 2022

CERTIFICATE OF SERVICE

On August 1, 2022, I electronically filed the foregoing with the Clerk of the Court for the United States Court of Appeals for the Fifth Circuit by using the appellate CM/ECF system. All participants in the case are registered CM/ECF users and that service will be accomplished by the appellate CM/ECF system.

/s/ Joshua J. Prince
Joshua J. Prince

CERTIFICATE OF COMPLIANCE

This Motion complies with the type-volume limitation of Fed. R. App. P. 27 because it contains 583 words, excluding the parts exempted by Fed. R. App. P. 32(f).

This Motion also complies with the typeface and type-style requirements of Fed. R. App. P. 32(a)(5)(A) and 32(a)(6), and 5th Cir. R. 32.1, because it has been prepared in a proportionally spaced typeface using Microsoft Word Office 2016 in 14-point Century Schoolbook font.

/s/ Joshua J. Prince
Joshua J. Prince

No. 20-51016

**United States Court of Appeals
for the Fifth Circuit**

MICHAEL CARGILL,

Plaintiff-Appellant,

v.

MERRICK GARLAND, U.S. ATTORNEY GENERAL; UNITED STATES
DEPARTMENT OF JUSTICE; STEVEN DETTELBACH, IN HIS OFFICIAL CAPACITY
AS DIRECTOR OF THE BUREAU OF ALCOHOL, TOBACCO, FIREARMS AND
EXPLOSIVES; BUREAU OF ALCOHOL, TOBACCO, FIREARMS AND EXPLOSIVES,

Defendants-Appellees.

On Appeal from the United States District Court
for the Western District of Texas, Austin Division
No. 1:19-cv-349

**BRIEF FOR *AMICI CURIAE* FIREARMS POLICY COALITION
AND FPC ACTION FOUNDATION SUPPORTING APPELLANT
AND REVERSAL**

Cody J. Wisniewski
FIREARMS POLICY COALITION
5550 Painted Mirage Road, Suite 320
Las Vegas, NV 89149

Joseph G.S. Greenlee
FPC ACTION FOUNDATION
5550 Painted Mirage Road, Suite 320
Las Vegas, NV 89149

Erik S. Jaffe
Joshua J. Prince
Counsel of Record
SCHAERR | JAFFE LLP
1717 K Street NW, Suite 900
Washington, DC 20006
(202) 787-1060
jprince@schaerr-jaffe.com

Counsel for Amici Curiae

August 1, 2022

**SUPPLEMENTAL STATEMENT OF INTERESTED PERSONS
AND RULE 26.1 DISCLOSURE**

No. 20-51016

Michael Cargill v. Merrick Garland, U.S. Attorney General, et al.

Pursuant to 5th Circuit Rule 29.2, the following listed persons and entities as described in the fourth sentence of Rule 28.2.1 have an interest in the outcome of this case. These representations are made in order that the judges of this Court may evaluate possible disqualification or recusal.

Amici Curiae:

1. Firearms Policy Coalition
2. FPC Action Foundation

Counsel for *Amici Curiae:*

Erik S. Jaffe, Esq.
Joshua J. Prince, Esq.
SCHAERR | JAFFE LLP

Cody J. Wisniewski
FIREARMS POLICY COALITION

Joseph G.S. Greenlee
FPC ACTION FOUNDATION

Amici are both nonprofit organizations, no *Amicus* has a parent corporation, and no publicly held corporation owns 10% or more of either *Amicus*.

/s/ Joshua J. Prince

Joshua J. Prince

Counsel of Record for Amici Curiae

TABLE OF CONTENTS

SUPPLEMENTAL STATEMENT OF INTERESTED PERSONS AND RULE 26.1 DISCLOSURE.....	i
TABLE OF AUTHORITIES.....	iv
IDENTITY AND INTEREST OF <i>AMICI CURIAE</i>	1
RULE 29(a)(4)(e) STATEMENT	2
INTRODUCTION AND SUMMARY	2
ARGUMENT	4
I. THE FINAL RULE AND THE DISTRICT COURT’S OPINION IGNORE THE INTRINSIC PHYSICS OF BUMP FIRING.....	4
II. “TRIGGER,” AS USED IN THE DEFINITION OF “MACHINEGUN,” IS UNAMBIGUOUS AND DOES NOT ENCOMPASS THE FOREBODY OF A SEMIAUTOMATIC WEAPON.	15
CONCLUSION.....	24
CERTIFICATE OF SERVICE.....	26
CERTIFICATE OF COMPLIANCE.....	27

TABLE OF AUTHORITIES

Cases

Cargill v. Barr,
 502 F. Supp. 3d 1163 (W.D. Tex. 2020) 10, 15, 21

Freedom Ordnance Mfg. v. Brandon,
 No. 3:16-cv-00243-RLY-MPB (S.D. Ind.)..... 14

Statutes and Regulations

18 U.S.C. § 921(a)(29)..... 15, 22

18 U.S.C. § 921(a)(5)..... 22

18 U.S.C. § 921(a)(7)..... 22

26 U.S.C. § 5845(b)..... 11, 16

ATF, *Bump-Stock-Type Devices*, 83 FED. REG. 66,514 (Dec. 26,
 2018)..... *passim*

Other Authorities

ATF’s Summ. J. Mem., ECF No. 61-1, *Guedes v. ATF*, No. 18-
 cv-02988-DLF (D.D.C.) 8

Br. in Supp. of Mot. for Summ. J., ECF No. 28,
Freedom Ordnance Mfg. v. Brandon, No. 3-16-cv-00243-RLY-
 MPB (S.D. Ind.)..... 14

Firearms Policy Coalition, *Image of AR-15 Trigger Mechanism*,
<http://publicfiles.firearmspolicy.org/ar15.gif>..... 17

Hallowell & Co., *Illustrated Firearms Dictionary*,
<https://tinyurl.com/4my6ws9z> 16

John Quick, *Dictionary of Weapons and Military Terms* (1973)..... 9

National Firearms Act: Hearings on H.R. 9066 before House
 Comm. on Ways and Means, 73rd Cong. (1934)..... 11

Patton Media and Consulting, LLC, *Bump Stock Analytical
 Video FPC/FICG*, YouTube (June 18, 2018),
<https://youtu.be/1OyK2RdO63U>..... 7

Pls.’ Statement of Facts, ECF No. 62-2, *Guedes v. ATF*,
 No. 18-cv-02988-DLF (D.D.C.)..... 7

R.A. Steindler, *The Firearms Dictionary* (1970)..... 16
The Oxford English DICTIONARY (1933) (1970 reprint) 9
The Shorter Oxford English Dictionary (3d ed. 1944) (1973
reprint) 9
Webster's New Twentieth Century Dictionary (2d. ed. 1964)..... 9

IDENTITY AND INTEREST OF *AMICI CURIAE*

Firearms Policy Coalition (FPC) is a nonprofit organization devoted to advancing individual liberty and defending constitutional rights. FPC accomplishes its mission through legislative and grassroots advocacy, legal and historical research, litigation, education, and outreach programs. FPC's legislative and grassroots advocacy programs promote constitutionally based public policy. Its historical research aims to discover the Founders' intent and the Constitution's original meaning. And its legal research and advocacy aim to ensure that constitutional rights maintain their original scope.

FPC Action Foundation (FPCAF) is a nonprofit organization dedicated to preserving the rights and liberties protected by the Constitution. FPCAF focuses on research, education, and legal efforts to inform the public about the importance of constitutional rights—why they were enshrined in the Constitution and their continuing significance. FPCAF is determined to ensure that the freedoms guaranteed by the Constitution are secured for future generations. FPCAF is one of the Plaintiffs/Appellants in *Guedes v. ATF*, No. 21-05045

(D.C. Cir.), another case challenging ATF’s bump stock rule and currently awaiting decision by the D.C. Circuit.

RULE 29(a)(4)(e) STATEMENT

No party’s counsel authored this Brief in whole or in part. Further, no party or party’s counsel contributed money that was intended to fund its preparation or submission. Finally, no person, other than *Amici* or their counsel, contributed money that was intended to fund the Brief’s preparation or submission.

INTRODUCTION AND SUMMARY

Amici agree with Appellant that, on the merits, the Final Rule should fall. ATF, *Bump-Stock-Type Devices*, 83 FED. REG. 66,514 (Dec. 26, 2018). They write separately here to expand upon two points. First, they provide additional information about the process of bump firing to highlight the absurdity of the Final Rule’s definition of “machinegun.” As the Supplemental Brief explains, at 4, bump firing can be done even without a bump stock. *Amici* here explain more fully how that is done and how any semiautomatic weapon can be bump fired by itself or with a multitude of commonly available materials that can make the process marginally easier. Given that the physics of such techniques are intrinsic

to virtually any semiautomatic weapon, ATF's definitions of "automatically" and of "single function of the trigger" would render *every* semiautomatic weapon a machinegun—an absurd result that cannot be squared with other statutory sections recognizing that semiautomatic weapons are a distinct and less-regulated category of weapons than machineguns.

Second, *Amici* address the district court's Orwellian conclusion that the "trigger" of a bump-stock-equipped weapon is something other than the universally understood mechanism that typically interacts with the human finger to release the hammer when depressed, bumped, or "pulled" and then, on a semiautomatic weapon, resets the firing mechanism when released. Reclassifying the forebody of a weapon as the trigger because forward pressure on the forebody causes the actual trigger to interact with a trigger finger held immobile both defies any recognizable public meaning of the language of the statute and leads to absurd results.

Because both ATF's and the district court's redefinitions of various terms within the definition of machinegun defy any cogent

understanding of those terms and lead to absurd results, they should be rejected, and the decision below should be reversed.

ARGUMENT

I. THE FINAL RULE AND THE DISTRICT COURT'S OPINION IGNORE THE INTRINSIC PHYSICS OF BUMP FIRING.

Bump stocks do not magically enable semiautomatic weapons to bump fire and do not turn them into machineguns. Rather, every semiautomatic weapon can be bump fired. “Bump firing” is simply a technique for sequentially causing the trigger to move back and forth through its range of motion by “bumping” the trigger into the trigger finger to depress it, then using the recoil energy of one shot to assist in moving the trigger *away* from a stationary finger, thus releasing the trigger and allowing it to reset and be ready for a subsequent operation or function of the trigger to fire the next shot. That the recoil from firing virtually any semiautomatic weapon tends to push the body of the weapon (and hence the trigger housing) backwards is simply a matter of intrinsic physics, and if the trigger finger is kept stationary relative to the forebody of the weapon, such recoil will disengage the trigger from the trigger finger thus allowing the trigger to reset. But a subsequent shot will not be fired unless the trigger is manually caused to bump the

trigger finger anew, leading to a second or subsequent function of the trigger and a second or subsequent shot being fired. Separating the movement of the trigger finger (or lack thereof) from the movement of the forebody of the firearm is just a matter of technique and can be accomplished with or without mechanical assistance.

ATF itself recognizes, for example, that skilled shooters can use this technique with nearly *any* semiautomatic firearm and with or without a bump stock. 83 FED. REG. at 66,532–33 (acknowledging thousands of comments showing that “bump firing” is a “technique that any shooter can perform with training or with everyday items such as” “rubber bands, belt loops, string, or even people’s fingers”). ATF’s definition of “automatically” redefines that term as not merely self-acting, but also as encompassing the far broader and malleable category of a self-regulating function that includes ample manual input. And it interprets the phrase “by a single function of the trigger” as covering only the *initial* function in a series of multiple functions of the trigger.

But ATF’s expanded definitions falter because ATF has failed to cogently explain why the definitions do not apply to all weapons that can be bump fired and to all combinations of everyday items that can ease or

facilitate bump firing. Because each subsequent function of the trigger is not dependent on *how* the trigger finger is kept fixed and independent of the forebody, ATF's new definition would apply to *any* weapon that can be bump fired, and any mechanical assist that could be combined with a semi-automatic weapon to make such firing technique easier. Thus, nearly every semiautomatic firearm in existence would be defined as a machinegun, ATF's arbitrary and irrational denials of that consequence notwithstanding.

A bump stock does nothing to alter the physics of bump firing or the ability of any semiautomatic weapon to be bump fired in precisely the same "self-regulating" manner initiated by the "initial" bump of the trigger that it claims occurs with ordinary bump stocks. All an unsprung bump stock does is provide some play between the forward portion of the firearm and the stock so that the recoil of any given shot can, depending on the amount of forward pressure being applied by the shooter, cause the forebody of the weapon (and hence the trigger) to slide backward and away from the trigger finger that remains unaffected by the recoil, thus releasing the trigger. It does *not* use that recoil to then re-engage the

trigger; the shooter herself must add additional manual input. Without such input, no further shots would be fired.¹

To fire a second shot, the shooter is required to push the forebody of the firearm forward again, thereby causing the trigger to “re-engage[]” the stationary trigger finger on the hand holding the stock. 83 FED. REG. at 66,533. A video verified by a former ATF administrator shows this process in action. Patton Media and Consulting, LLC, *Bump Stock Analytical Video FPC/FICG*, YouTube (June 18, 2018), <https://youtu.be/1OyK2RdO63U>; see also Pls.’ Statement of Facts ¶ 1, ECF No. 62-2, *Guedes v. ATF*, No. 18-cv-02988-DLF (D.D.C.).

To avoid the obvious mismatch between the statute and the actual operation of bump firing in general and bump stocks in particular, ATF argued in *Guedes* that a bump stock allows a firearm to “function automatically” by making it “easier to bump fire” because it controls recoil and ensures more linear motion of the firearm. ATF’s Summ. J.

¹ A bump stock with an internal spring, by contrast, would capture the recoil energy in the spring and then use that energy, rather than manual input, to force the trigger forward and into renewed contact with the trigger finger. While that might be an automatic means of causing multiple functions of the trigger, this case only concerns unsprung bump stocks which do not have such self-acting mechanisms.

Mem. at 14, ECF No. 61-1, *Guedes v. ATF*, No. 18-cv-02988-DLF (D.D.C.). Making it easier to bump fire a firearm, however, is neither the test in the statute nor in the Final Rule. It does not speak to whether each subsequent round requires an additional function of the trigger to fire. Nor does it explain why making the operation of a weapon “easier” makes the shooting automatic or means that it is occurring via a self-acting mechanism. Indeed, the Final Rule’s expansion of the phrase “shoot ... automatically” to encompass not merely shooting by a “self-acting” mechanism, but also by an indecipherably vague and malleable “self-regulating” mechanism, has no historical, grammatical, or contextual support. 83 FED. REG. at 66,533. In context, an “automatic” firearm has always been understood as one that would continue shooting so long as the trigger was pressed and held, not one that required the trigger to be released and re-engaged for each shot.

At the time of the 1968 GCA and the 1934 NFA, “automatically” was understood as referring to the operation of a “self-acting” mechanism—not merely a vaguely “self-regulating” mechanism. An automatic firearm was understood as a firearm that fired continuously until the trigger was released or the ammunition exhausted. *See, e.g.,*

Webster's New Twentieth Century Dictionary 127 (2d. ed. 1964) (defining “automatic” and “automatical” as “1. Conducted or carried on by self-acting machinery; as, automatic operations.”; defining “automatic pistol, automatic rifle, etc.” as “a pistol, rifle, etc. that uses the force of the explosion of a shell to eject the empty cartridge case and place the next cartridge into the breech so that shots are fired in rapid succession until the trigger is released.”); *The Shorter Oxford English Dictionary* 135 (3d ed. 1944) (1973 reprint) (defining “Automatic,” in relevant part, as “1. lit. Self-acting, having the power of motion or action within itself 1812. 2. Going by itself; esp. of machinery and its movements, which produce results otherwise done by hand, or which simulate human or animal action 1802.”); 1 *The Oxford English Dictionary* 574 (1933) (1970 reprint) (defining “Automatic,” in relevant part, as “1. lit. Self-acting, having the power of motion or action within itself. ... 2. Self-acting under the conditions fixed for it, going of itself. Applied esp. to machinery and its movements, which produce results otherwise done by hand[.]”); cf. John Quick, *Dictionary of Weapons and Military Terms* 40 (1973) (defining “automatic fire” as “continuous fire from an automatic gun, lasting until pressure on the trigger is released”).

Although ATF does not appear to be using the clumsy formulation here that it did in *Guedes*, ATF's arguments otherwise mirror the errors it has made elsewhere. At best, the fact that bump firing is easier with a bump stock relates to the legally irrelevant point that bump stocks help shooters to better stabilize the firearm or separate the recoil of the forebody from the positioning of the trigger finger. It does not, however, lead to the "automatic" shooting of multiple rounds from that firearm. Indeed, *any* stock stabilizes a rifle in much the same way—it controls the distance and linearity of recoil.² Given that ATF and the district court suggest that other means of facilitating the bump firing of a semiautomatic firearm do not convert that firearm into an illegal machinegun, *e.g.*, 83 FED. REG. at 66,533; *Cargill v. Barr*, 502 F. Supp. 3d 1163, 1195 (W.D. Tex. 2020) (obvious subsequent history omitted), it is impossible to find a statutory basis for why this one means of making

² Similarly, other simple physical aids, such as a belt-loop, a rubber band, or even a padded shooting jacket can facilitate bump firing by constraining movement of the firearm, allowing the trigger finger to be held still independent of the recoil, maintaining linearity during recoil, controlling the distance of recoil, and myriad other things a shooter otherwise could do on their own. But stabilizing a weapon is a far cry from automatically firing such a weapon, otherwise *every* stock, grip, or bipod would make a semiautomatic weapon a machinegun.

such action easier has crossed some new yet unknowable line from semiautomatic to automatic, *see* 26 U.S.C. § 5845(b) (defining “machinegun” as “any weapon which shoots ... automatically more than one shot, without manual reloading, by a single function of the trigger” and also as including “any combination of parts from which a machinegun can be assembled if such parts are in the possession or under the control of a person”).

Indeed, because ATF admits that virtually all semiautomatic rifles can be “bump fired” with or without a bump stock, and often with the use of common household items—or even one’s finger—ATF’s definition would render all such firearms illegal as machineguns themselves or, when possessed along with common household items or even just pants with belt loops, a “combination of parts from which a machinegun can be assembled.” That is plainly beyond the original public understanding of the statutory language and hence unreasonable. *See* National Firearms Act: Hearings on H.R. 9066 before House Comm. on Ways and Means, 73rd Cong. 40–41 (1934) (Karl Frederick’s congressional testimony) (precursor phrase “with one function of the trigger” necessarily included in the definition of a machinegun “[b]ecause that is the essence of a

machine gun. Otherwise you have the ordinary repeating rifle ... which is in no sense and never has been thought of as a machine gun.”). ATF’s definitions effectively obliterate the well understood distinction between semiautomatic and automatic weapons.

In issuing the Final Rule, ATF also sought to dodge the obvious fact that bump firing a semiautomatic weapon involves multiple functions of the trigger by claiming that the *first* function of the trigger initiated a “firing cycle” that required no further affirmative action by the shooter and hence no further “pull” of the trigger. 83 FED. REG. at 66,534–35. But that, too, is absurd, even on its own flawed terms. Subsequent shots indeed require affirmative action by the shooter in pushing the body of the firearm forward to bump the trigger into the finger. And regardless of *how* subsequent functions of the trigger are accomplished, the trigger must release and then interact with the trigger finger again each time a shot is fired. That involves multiple functions of the trigger, regardless of whether such functions are somehow part of a cycle. (Indeed, wagging one’s trigger finger back and forth or in a small circle is no less cyclic yet equally involves multiple functions of the trigger.)

Moreover, even with a bump stock, a shooter must put forth a near exact amount of pressure on the body of the firearm to cause the trigger to re-engage with the trigger finger after each reset—too much forward pressure and the trigger will be unable to reset because the pressure will counteract the recoil; too little and the trigger will not be brought back to the stationary trigger finger with sufficient force to push the trigger back and release the hammer for the next shot. Thus, unlike operating a machinegun, bump firing takes a significant amount of ongoing manual interaction, skill, and very intentional movements to effectuate.

Given these facts, suggesting that the “firing cycle” of repeatedly bumping the trigger into the trigger finger through the manual exertion of forward pressure is accomplished by a “single” function of the trigger merely because it is “initiated” by the first function of the trigger is simply wrong. Indeed, that suggestion is akin to saying that a journey of a thousand steps is *initiated* by a single step and therefore *accomplished* by that step.

ATF itself aptly explained why bump stocks are *not* machineguns for years under a proper understanding of bump firing. Indeed, from 2008 to 2017, ATF consistently and repeatedly asserted that bump stocks are

not machineguns and do not convert semiautomatic firearms into machineguns in ten different letter rulings, *e.g.*, 83 FED. REG. at 66,517, and in court. In *Freedom Ordnance Manufacturing v. Brandon*, No. 3:16-cv-00243-RLY-MPB (S.D. Ind.), for example, ATF argued that unsprung bump stocks were not machineguns because bump firing:

requires the shooter to manually pull and push the firearm in order for it to continue firing. Generally, the shooter must use both hands—one to push forward and the other to pull rearward—to fire in rapid succession. While the shooter receives an assist from the natural recoil of the weapon to accelerate subsequent discharge, the rapid fire sequence in bump firing is contingent on shooter input in pushing the weapon forward, rather than mechanical input, and is thus not an automatic function of the weapon.

Br. in Supp. of Mot. for Cross-Motion for Summ. J. at 22, ECF No. 28.

ATF was right then, and this Court should not let ATF's sudden about-face and manufactured obfuscation regarding the intrinsic nature of bump firing continue to threaten criminal liability on law-abiding gunowners in the United States. Because virtually all semiautomatic weapons can be bump fired, and because that technique can be aided by myriad common household products or clothing items, ATF's definition is necessarily overbroad and would eliminate statutory distinctions between less-regulated semiautomatic rifles and handguns, and more-

regulated machineguns. *See, e.g.*, 18 U.S.C. § 921(a)(29) (defining “semiautomatic rifles” as, among other things, “requir[ing] a separate pull of the trigger to fire each cartridge”). Bump firing, whether aided by a bump stock, a rubber band, or merely a well-controlled finger, is not shooting automatically and the ease with which any given weapon can be bump fired does not turn semiautomatic firearms into heavily regulated machineguns.

II. “TRIGGER,” AS USED IN THE DEFINITION OF “MACHINEGUN,” IS UNAMBIGUOUS AND DOES NOT ENCOMPASS THE FOREBODY OF A SEMIAUTOMATIC WEAPON.

The district court also misunderstood what a trigger is when it treated the “fore-grip” or the “barrel shroud” of the firearm as the trigger. In the process, it concluded that “there is no meaningful difference” between the “constant forward pressure” used when bump firing, *see* Section I, and the constant pressure on the trigger itself when firing an automatic weapon, *Cargill*, 502 F. Supp. 3d at 1193–94. This is wrong on all counts.

For starters, the term “trigger,” as used in both the National Firearm Act and Gun Control Act’s definitions of “machinegun,” is unambiguous. 26 U.S.C. § 5845(b). It specifically refers to the part of the

firearm that is pulled (or pushed or otherwise made to traverse its range of motion) to release the action of that firearm. Hallowell & Co., *Illustrated Firearms Dictionary*, <https://tinyurl.com/4my6ws9z> (defining “trigger” as the “small lever on a cartridge firearm, which one pulls to cause the spring-loaded firing pin to impact the primer, causing the gun to discharge”); R.A. Steindler, *The Firearms Dictionary* 259 (1970) (defining “trigger” as “usually a curved, sometimes grooved or serrated, metal bar that, when pulled *rearward*, releases its engagement on the sear ... or hammer ..., thus firing the gun” (emphasis added)). In a semiautomatic firearm, once pulled, the trigger is then released to reset the action of the firearm; in a machinegun, the trigger can remain depressed, and the action of the firearm will cycle automatically.

Understanding the functionality of a trigger requires a basic grasp on firearm functionality that the court below lacked. At the core of a semiautomatic rifle is the bolt. The bolt ensures that an ammunition shell stays firmly in place so that sufficient energy pushes the bullet down the barrel, rather than simply pushing the bolt backward. In a single shot or manually repeating firearm, the bolt stays firmly locked in place during firing, whereas a semiautomatic firearm uses some energy

from the fired round to cause the bolt to reciprocate or move rearward. Inside the bolt is the firing pin. The firing pin, which comes to a point towards its breech end (towards the face of the bolt where it contacts the ammunition), is what strikes the primer, causing the propellant inside an ammunition casing to combust and producing the explosion that propels the bullet.

As illustrated below, the trigger mechanism of a semiautomatic firearm consists of a trigger, a hammer, and a disconnecter.³ Image 1.

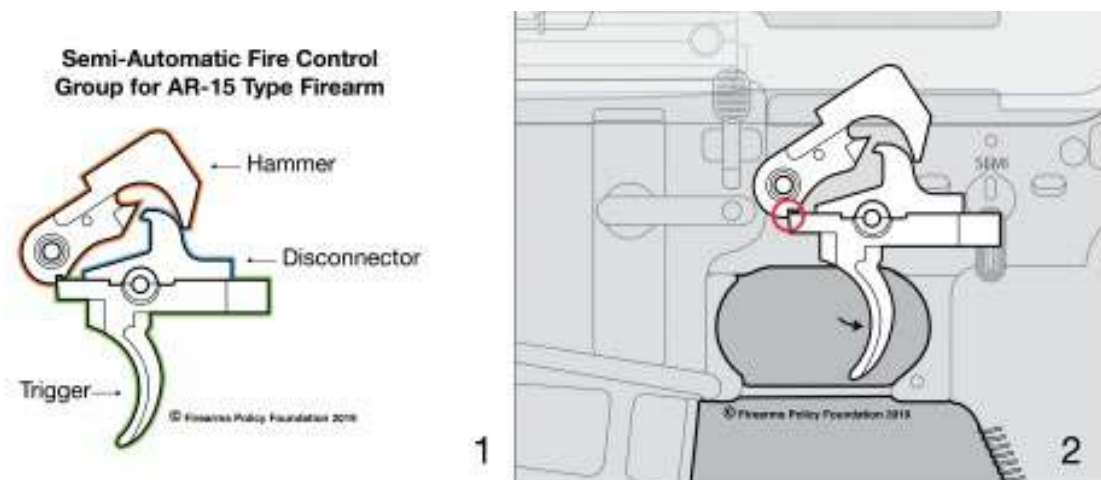

The hammer is spring-loaded, storing energy as it is moved rearward into the “cocked” position. The trigger keeps the hammer in the “cocked” position by way of its “sear,” a geometric plane that locks the

³ The process can be viewed at Firearms Policy Coalition, *Image of AR-15 Trigger Mechanism*, <http://publicfiles.firearmspolicy.org/ar15.gif>.

trigger and hammer together. Image 2. When the trigger is depressed, the trigger sear slides out of the way of the hammer, allowing the hammer to swing and strike the firing pin. Image 3.

The hammer then strikes the firing pin and results in a single round being discharged. Image 4.

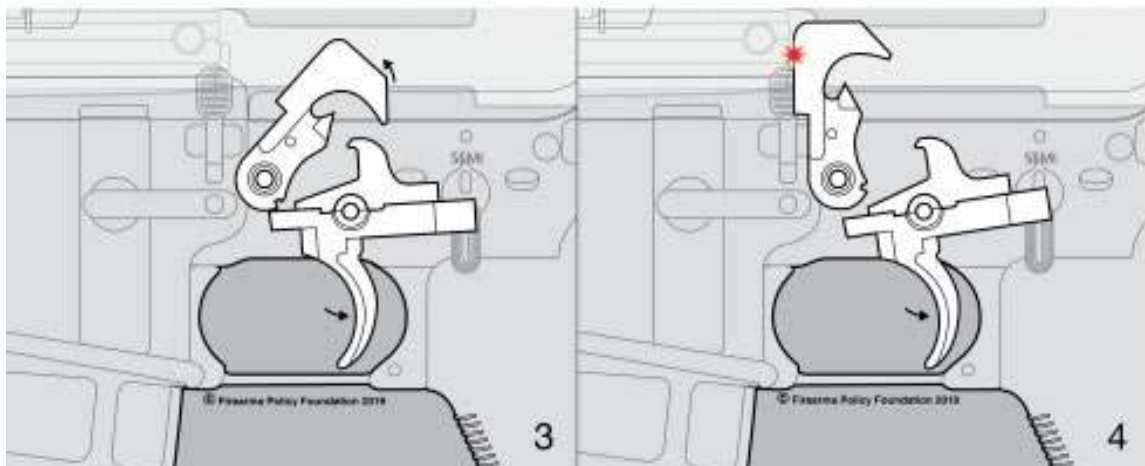

In a semiautomatic firearm, the bolt re-cocks the hammer. By the time the bolt reciprocates, the operator may still have the trigger depressed. This is where the “disconnecter” comes into play. When the trigger is depressed, the disconnecter moves into its active state. Image 5. When the weapon fires, the bolt travels rearward, pushing the hammer to the rear. The disconnecter captures the hammer near its rearmost position. Images 6.

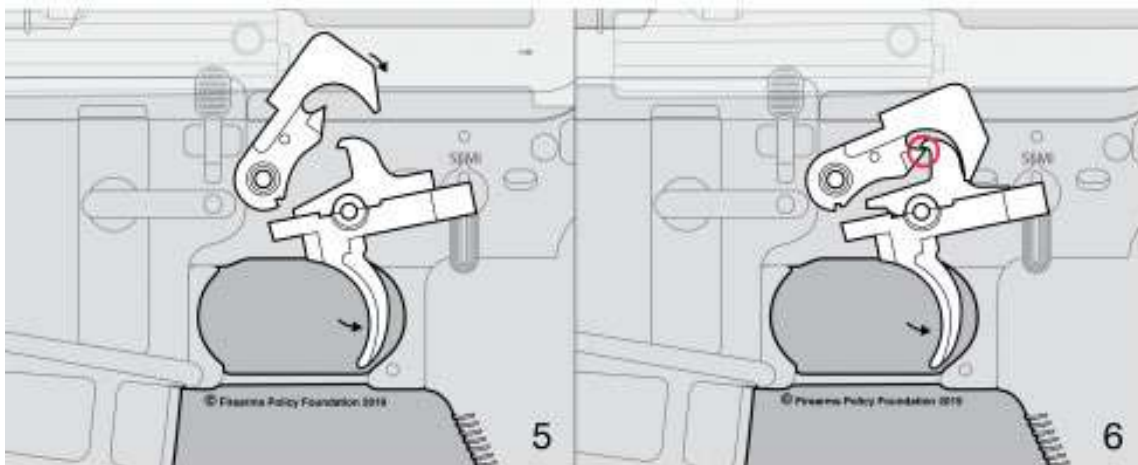

Then, as the operator releases the trigger, the hammer slips off the disconnecter and back onto the trigger's sear, where it is ready to be fired again. Image 7.

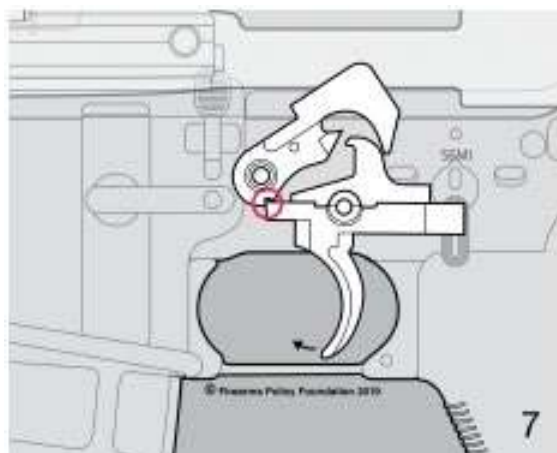

Were it not for the disconnecter, upon firing, the bolt would push the hammer rearward, but as the bolt returned forward under spring pressure, the hammer would “follow” the bolt as it returns to battery, failing to re-cock the hammer or to strike the firing pin with sufficient force to discharge a subsequent round. Absent extraordinary

circumstances, this creates a need to manually re-cock the hammer. Accordingly, a typical semiautomatic firearm would not become a “machinegun” even absent a disconnecter.

A weapon failing to fire a subsequent shot because the hammer was not re-cocked experiences what is known as a “hammer follow” malfunction. This can happen in a typical semiautomatic firearm when the trigger is released and depressed again before the bolt travels all the way forward. It can happen as an ordinary result of rapid semiautomatic firing, be it from depressing the trigger too quickly, “bump firing,” or otherwise.

For a true machinegun, the “hammer follow” problem is one of precise timing. If the hammer is released too early, the hammer will follow the bolt and the firearm will not fire, needing to be manually re-cocked. If released too late, the bolt will lose forward travel before tripping the mechanism. This issue of timing is handled in machineguns by an “auto sear.”

The “auto sear” is designed to hold the hammer in the “cocked” position until the firearm’s bolt has returned all the way forward to battery. The auto sear then releases the hammer and discharges the

weapon again. No additional input is needed from the operator. With an auto sear mechanism, if the trigger is depressed, the weapon will fire continuously and (fairly) consistently until ammunition is depleted.

Thus, a machinegun equipped with an automatic fire mechanism contains a “self-acting” mechanism, which upon simply keeping the trigger depressed, without any further input, will fire successive rounds without “hammer follow.” The district court correctly understood this point. *Cargill*, 502 F. Supp. 3d at 1193–94.

But the district court missed that for a semiautomatic weapon (which does not contain an auto sear), even when being bump fired, the key point of operator input in this entire process is multiple functions of the trigger. It must be depressed for the first shot and then released and depressed again for each subsequent shot. The trigger is the mechanism that, when depressed by pulling, bumping, or otherwise, releases the hammer and causes a shot to be fired. If not released, reset, and then depressed again, no subsequent shot will be fired. Only through repeated operator input will a semiautomatic firearm shoot, and the trigger must be re-engaged anew for each shot, even when bump firing.

While federal law does not specifically define “trigger,” it does refer to a “trigger” several times—all of which demonstrate this same unambiguous understanding of the term. The federal definition of “rifle” is a weapon “fir[ing] only a single projectile through a rifled bore for each single *pull of the trigger*.” 18 U.S.C. § 921(a)(7) (emphasis added). Similarly, the federal definition of “shotgun” explains that a shotgun fires “through a smooth bore either a number of ball shot or a single projectile for each single *pull of the trigger*.” 18 U.S.C. § 921(a)(5) (emphasis added). The same is true of a “semiautomatic rifle,” which fires “each cartridge” with “a separate *pull of the trigger*.” 18 U.S.C. § 921(a)(29) (emphasis added). Each of those references are consistent with the common dictionary definitions discussed above, and inconsistent with the district court’s effort to redefine what constitutes a trigger.

Given the above discussion of the firing mechanism of a typical semiautomatic weapon, the common public understanding of the word *trigger* is the physical lever that, when moved through its range of motion, releases the hammer to fire a round. And when the trigger itself is allowed to return to its starting position in a semiautomatic weapon, it resets the hammer in preparation for a subsequent function of the

trigger. The district court's suggestion that the forebody of a bump-stock-equipped semiautomatic weapon somehow magically transforms into the trigger ignores the operation of all semiautomatic firearms. And it leads to the absurdity that the actual trigger is not the trigger anymore, or that there are *two* triggers that must operate in conjunction to fire the weapon at all. After all, pressure on the forebody of a weapon with or without a bump stock will not cause it to fire unless the trigger finger is also placed on the mechanism-formerly-known-as-the-trigger (perhaps denominated with a suitably unpronounceable glyph or referred to as the Trigger That Shall Not Be Named) and that mechanism runs through multiple functions of depression and release. Alternatively, if there are *two* nominal triggers, one that receives constant (though constantly titrated and modulated) forward pressure but that is ineffective unless the other engages in multiple functions through pressure and release, then it is impossible to know which trigger the statute refers to when discussing a single function of "the trigger." And, of course, even without a bump stock, bump firing requires the identical forward pressure on the forebody of the weapon, thus making all forebodies the "trigger" of any

bump-fire-capable weapon under the district court's overbroad and absurd definition of the word "trigger."

Given that both ATF's and the district court's definitions and interpretations are overbroad and lead to absurd results, they should be squarely rejected, and this Court should recognize that even with a bump stock, semiautomatic weapons require multiple manual functions of the trigger to fire multiple shots, and hence are not machineguns.

CONCLUSION

For the foregoing reasons, *Amici* join Appellant in requesting that this Court reverse the decision below and instruct the district court to enter judgment for Appellant.

Respectfully submitted,

/s/ Joshua J. Prince

Erik S. Jaffe

Joshua J. Prince

Counsel of Record

SCHAERR | JAFFE LLP

1717 K Street NW, Suite 900

Washington, DC 20006

(202) 787-1060

jprince@schaerr-jaffe.com

Cody J. Wisniewski

FIREARMS POLICY COALITION

5550 Painted Mirage Road,

Suite 320

Las Vegas, NV 89149

Joseph G.S. Greenlee

FPC ACTION FOUNDATION

5550 Painted Mirage Road,

Suite 320

Las Vegas, NV 89149

Counsel for Amici Curiae

Dated: August 1, 2022

CERTIFICATE OF SERVICE

On August 1, 2022, I electronically filed the foregoing with the Clerk of the Court for the United States Court of Appeals for the Fifth Circuit by using the appellate CM/ECF system. All participants in the case are registered CM/ECF users and that service will be accomplished by the appellate CM/ECF system.

/s/ Joshua J. Prince
Joshua J. Prince

CERTIFICATE OF COMPLIANCE

The foregoing Brief complies with the type volume limitation of Fed. R. App. P. 29(a)(5) and 32(a)(7)(B), and 5th Cir. R. 32.2, because it contains 4,538 words, excluding the parts of the brief exempted by Fed. R. App. P. 32(f) and 5th Cir. R. 32.2.

This Brief also complies with the typeface and type-style requirements of Fed. R. App. P. 32(a)(5)(A) and 32(a)(6), and 5th Cir. R. 32.1, because it has been prepared in a proportionally spaced typeface using Microsoft Word Office 2016 in 14-point Century Schoolbook font.

/s/ Joshua J. Prince
Joshua J. Prince